

External cladding – technical instructions

Contents

External cladding – technical instructions	1
General.....	2
Vertical cladding	3
Horizontal cladding	5
Lower end of the cladding and the plinth.....	7
Upper end of the cladding and eaves	8
Corners.....	10
Storage	12
Working and fixing	12
Extensions	12
Additional information and source	13

General

Primary requirements for functional and durable external cladding:

- Use cladding boards of adequate thickness (minimum 19 mm)
 - Fix the boards with the heartwood on the weather side
 - Chamfer the lower ends of the cladding boards to allow water to run off freely
 - Leave a ventilation gap of 22 to 25 mm behind the cladding all the way from top to bottom
 - The plinth should be high enough to ensure that the lower end of the cladding is at least 300 mm from the ground
-
- Proper external window sills and architraves/ weatherboards
 - Proper gutters and downpipes
 - Minimum eaves width 30 mm, preferably 600 mm
 - Regular maintenance of the external cladding finish

Vertical cladding

When using timber for vertical cladding applications, place the heartwood on the weather side. Also consider the direction of growth rings and any 'fluff' that may have developed on the surface by placing the boards with the growth rings and fluff pointing down.

2 Installation of cladding boards. Vertical cladding boards are placed with the growth rings pointing down. Additionally, it is advisable to have the heartwood on the weather side.

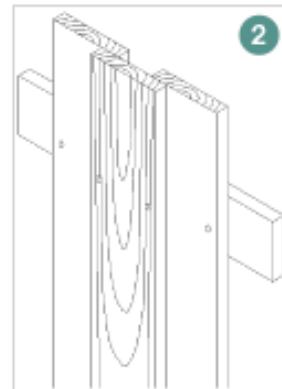

Traditional vertical cladding methods include strip-covered and staggered sidings. A staggered siding is normally made of unfinished overlapping boards. With strip-covered sidings, a narrow strip of wood is nailed on top to cover the gap between the boards. Paint or at least prime the boards closest to the wall before fixing the top boards in position or use industrially primed timber.

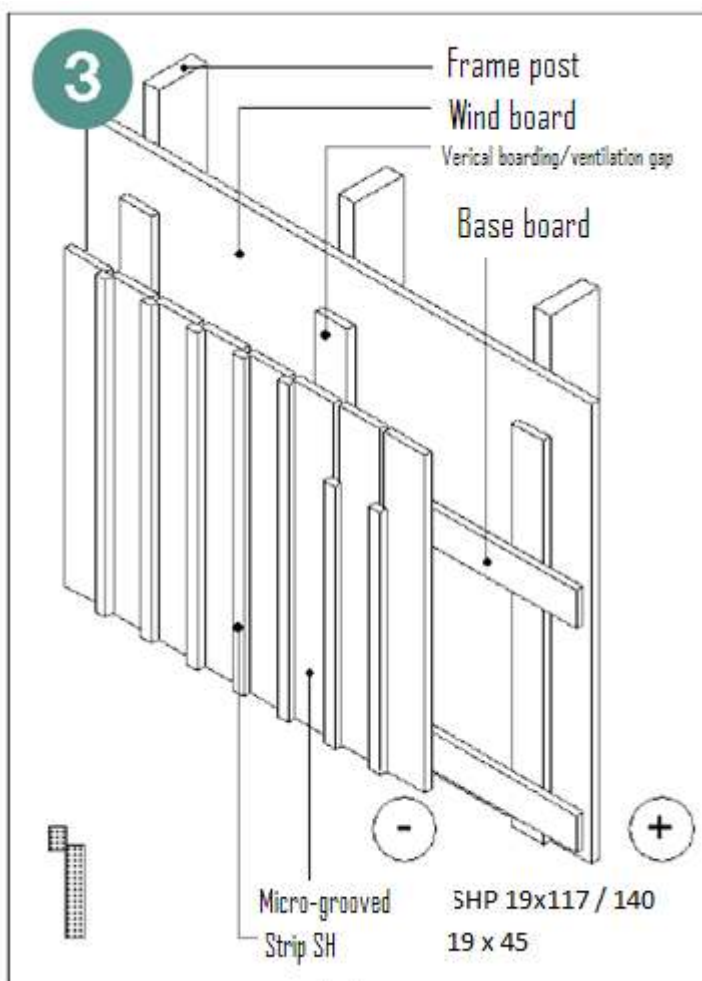

3 Example of strip-covered siding. Chamfer the lower ends of the boards and strips to allow water to run off freely.

For vertical cladding, use planed half or full tongue-and-groove cladding boards such as UTS and UTV-profiled boards.

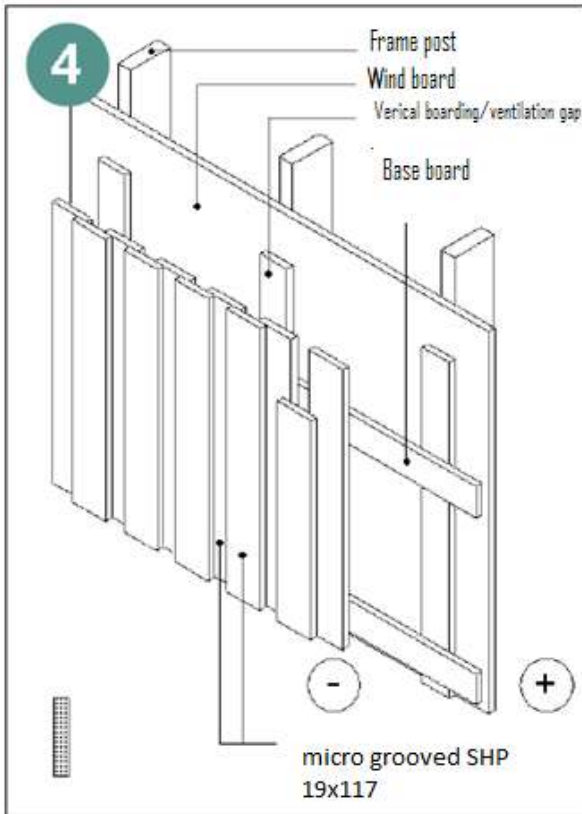

4 Example of a staggered siding.
Chamfer the lower ends of the boards to allow water to run off freely.

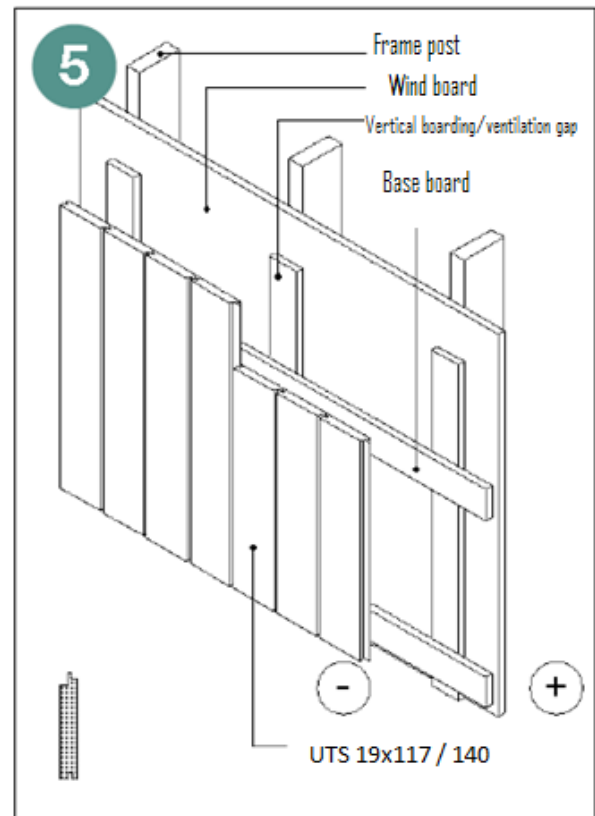

5 Example of vertical cladding.
Cladding board UTS 28x170. Chamber the lower ends of the boards to allow water to run off freely.

Horizontal cladding

The horizontal cladding boards are pre-formed planed half or full tongue-and-groove boards intended for use as horizontal cladding, such as UTV-, UTS-, UYK- and UYL-profiled boards. The UYK- and UYL-profiled cladding boards are intended for use in staggered sidings.

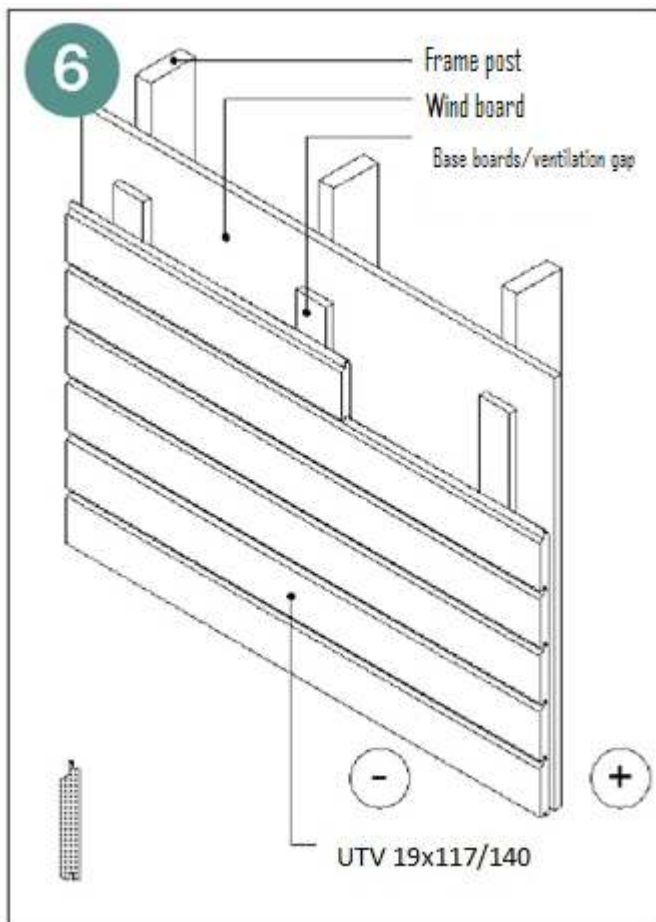

6 Example of horizontal cladding.
Cladding board UTV 19x117/140.

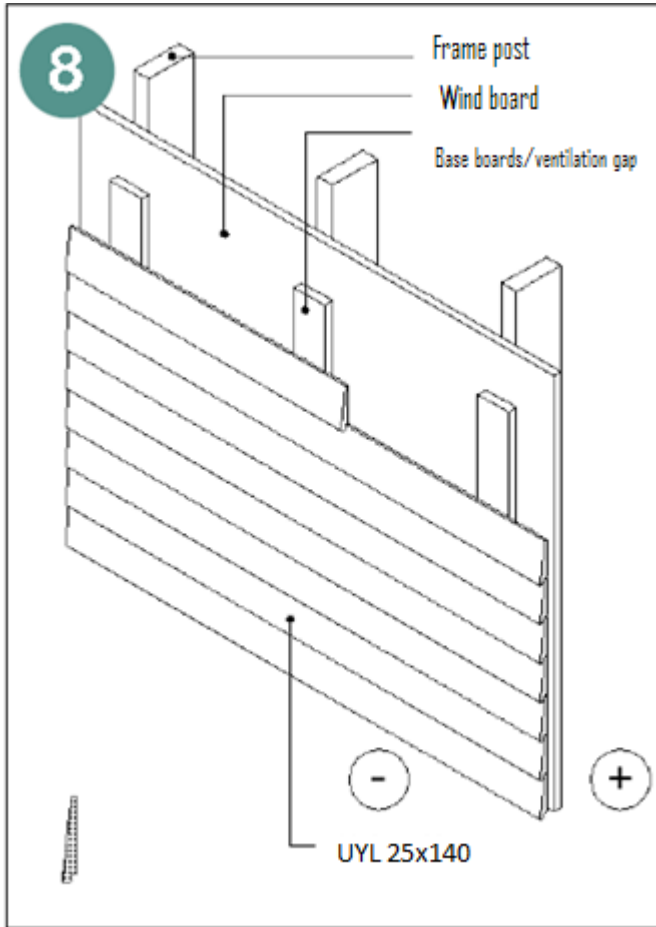

8 Example of staggered horizontal cladding.
Cladding board UYL 25x140.

Lower end of the cladding and the plinth

The height of the plinth of the building should be determined so as to ensure that the lower of the cladding is at least 300 mm from the ground. Prepare the ground to create a slope away the building (a minimum drop of 15 cm over a distance of 3 metres). Chamfer the lower ends of the vertical cladding boards to allow water to run off freely. Similarly, the lower edge of the bottom horizontal board can be chamfered to allow water to run off freely.

When painting, also remember to finish the pointed edge with special care. The lower end of the external cladding should extend a few centimetres beyond the top of the plinth. Also make sure that the 22 to 25 mm ventilation gap to be left behind the cladding remains open at the lower end to ensure adequate air circulation.

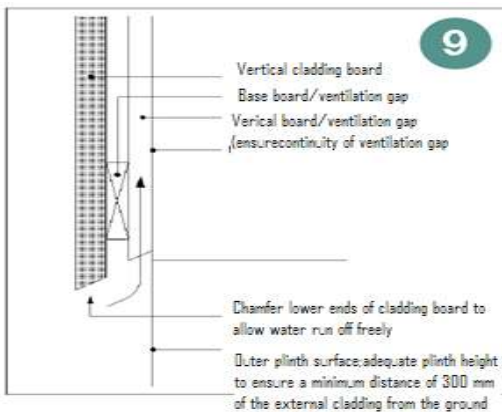

9 Lower end of vertical cladding/ventilation gap.
Chamfer the lower ends of the boards to allow water to run off freely and apply paint for weather protection.

10

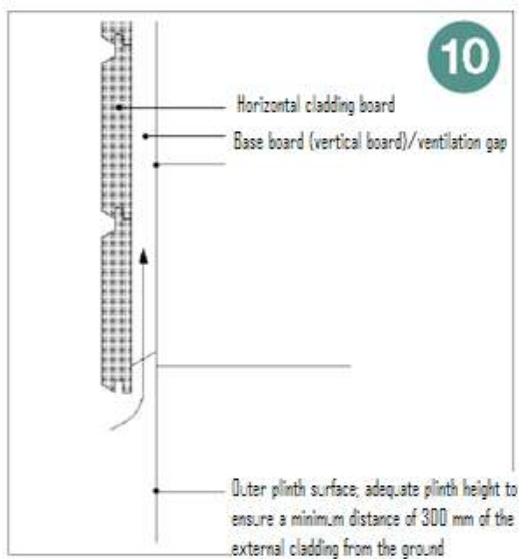

Lower end of horizontal cladding/ventilation gap. Apply paint to the lower end for weather protection.

Upper end of the cladding and eaves

Eaves provide efficient protection against rain. The recommended minimum width of the eaves is 600 mm. Leave a ventilation gap of at least 20 mm between the roof deck and cladding along the whole length of the wall to ensure adequate air circulation through the cladding substrate ventilation gap and the roof structure. If you fix boards to the underside of the eaves, leave 10 mm gaps between the boards to ensure that the ventilation system works as a whole.

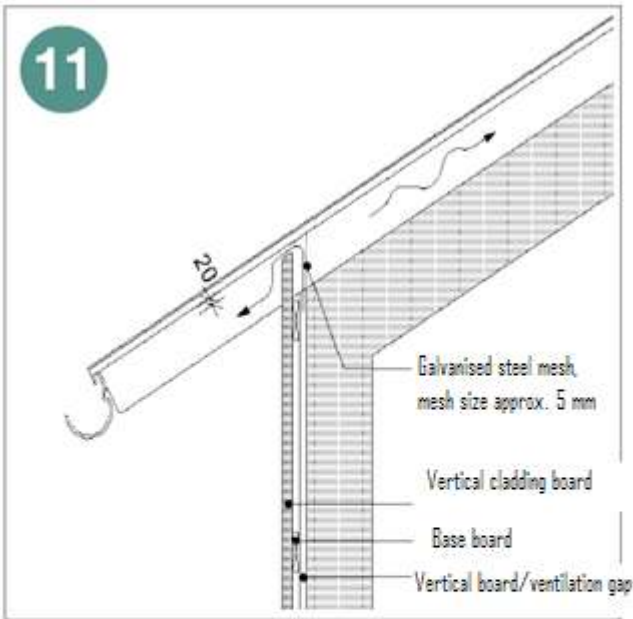

11 Connection of vertical cladding to the eaves. If the underside of the eaves is left open, the upper ends of the vertical boards must be finished with care.

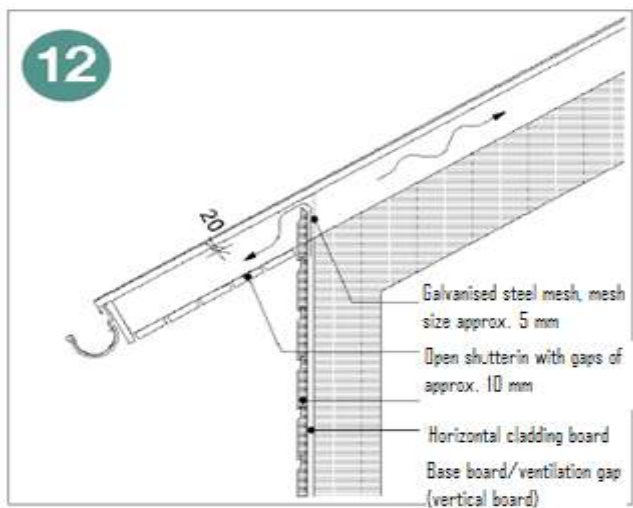

12 Connection of horizontal cladding to the eaves. Open shuttering on the underside of the eaves should be fixed so as to ensure that it will not prevent adequate ventilation behind the external cladding or inside the roof.

Corners

Think about how many corner boards you need and how wide they should be. Corner boards are usually for finishing the corners particularly in case of horizontal cladding while at the same time they accentuate the corners of the building, especially if they are painted in a colour different from the rest of the cladding.

Vertical cladding, in particular, is easy to install without special corner boards. Calculate the number of boards required for the wall involved to ensure that boarding can be evenly spaced and the boards to be fixed to the corners are wide enough.

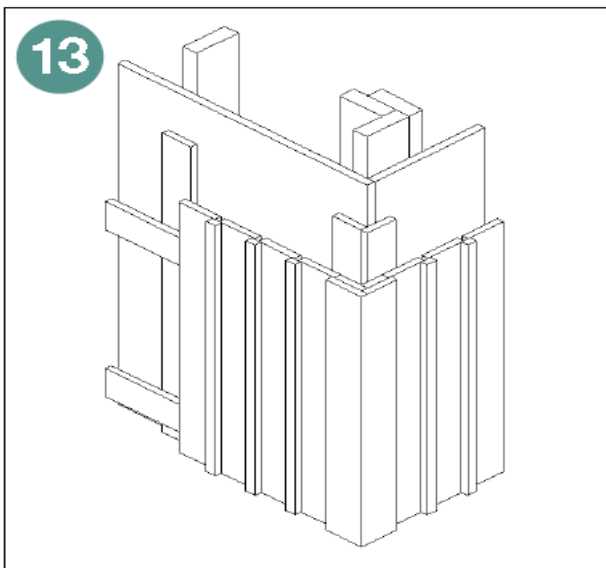

13 Corner/strip-covered cladding. Corners can also be finished without corner boards by 'wrapping' the cladding around the corner.

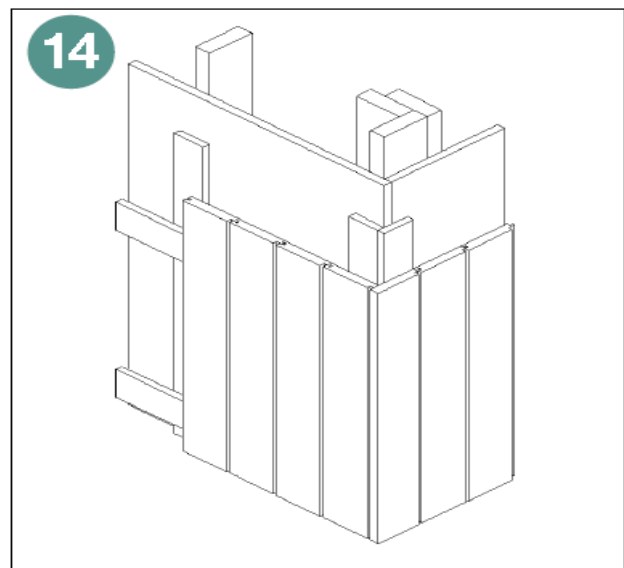

14 Corner/vertical cladding with UTS cladding boards. Cladding is 'wrapped' around the corner.

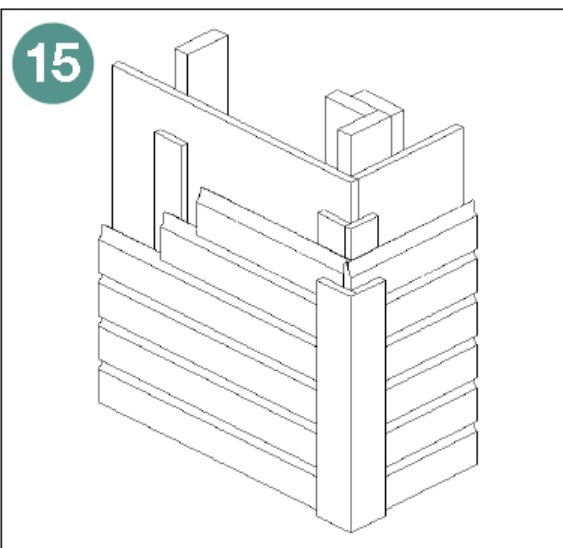

15 Corner/vertical cladding with UTK boards. Corners can also be finished without corner boards by mitre-cutting the board ends.

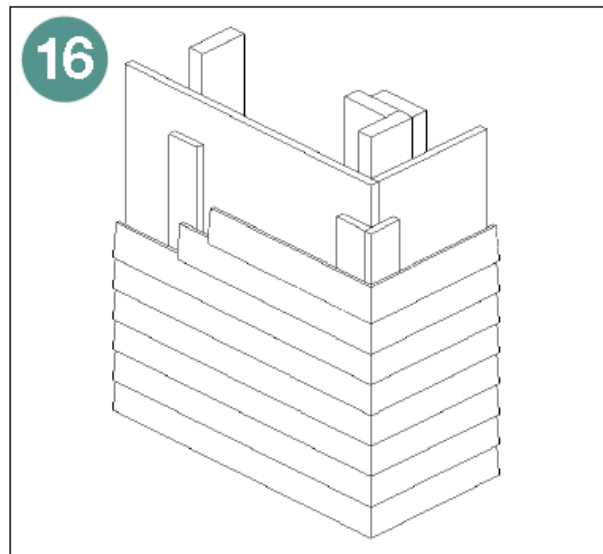

16 Mitre-cut corners with UYL cladding boards. Great accuracy in measurements and sawing is necessary. Corners can also be fitted with corner boards with the ends cut straight.

If vertical cladding is installed without corner boards, great care is required in mitre-cutting the ends and cutting the boards to the right length. To make the mitre joint weatherproof on the outside, leave a gap of about 2 mm on the wall side. Paint the mitred joints just like all the other extension joints before fixing the boards in position.

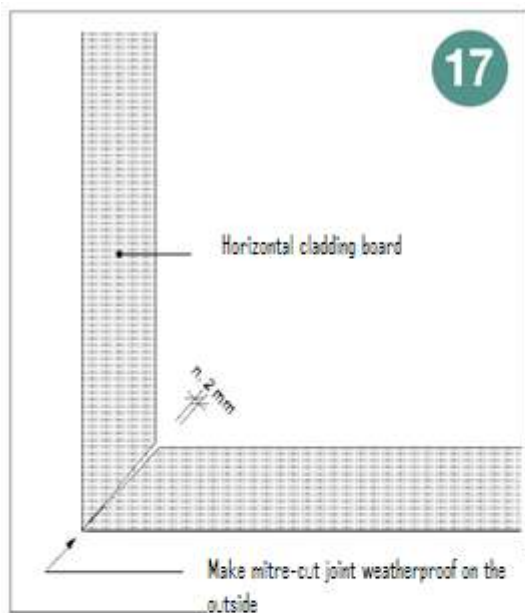

17 Mitre-cut outer corner joint of horizontal cladding, horizontal section. The boards are cut to leave a 2 mm gap on the reverse side.

Storage

Claddings boards must be protected from moisture, dirt, sunlight, ground contact, mechanical impact and scratching in transit and storage. Stack the boards face down on a straight level surface on top of transverse wood members spaced at 60 cm. Remove the steel hoops around the stacks and cover with protective board, etc.

Working and fixing

Cladding boards can be worked with conventional wood-working tools. Mitre-cut joints and cutting to length can best be accomplished with an electric crosscut saw fitted with a tilting disc and a circular saw.

As a rule, cladding boards are fixed to the substrate with hot-dip zinc-coated wire nails. Usually the suitable minimum nail length is 75 mm (see Nailing Instructions). Normal spacing of fixing points (base boards) is 600 mm. Use two nails to fasten the board at each fixing points located 20 to 25 mm from the board edge.

For installing the horizontal cladding, fix vertical base boards (thickness 22 to 25 mm) firmly through the wind board to the external wall frame posts. With vertical cladding, the base boards are placed horizontally and fixed firmly through the raiser strips or boards required for ventilation and the wind boarding to the frame posts.

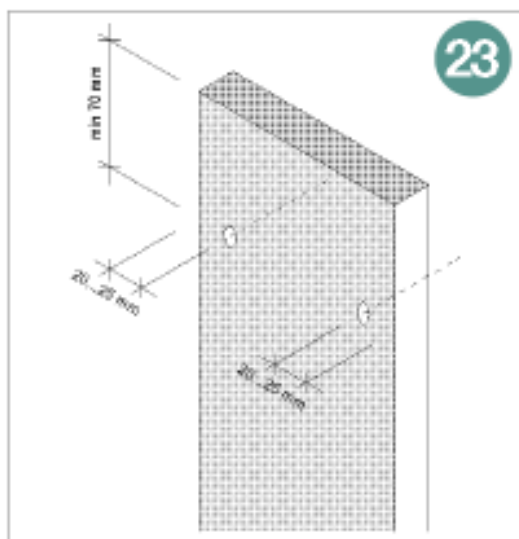

Base boards and ventilation of the space behind the cladding is illustrated in the examples in Figs. 3 through 12. Nailing instructions are provided in Fig. 23.

If you use a pneumatic nailer, make sure that the nail does not penetrate too deep to damage the wood surface. The head of the nail must not make a dent because it will make the wood absorb moisture. Use a nailer intended for external cladding and annular ring shanked nails to adjust the nailing depth.

If the nail is to be fixed closer than 70 mm from the end of a board, drill holes before nailing to prevent cracking.

Extensions

Avoid extensions where possible. Cladding boards with tongued-and-groove ends are also available, which makes it possible to butt-joint boards at any point and reduce wastage. If extensions are necessary, make sure that absorption of water through the cut-off surface into the wood is effectively prevented. Make the extension as weatherproof as possible or cover it with a strip or flashing or paint the cut-off surfaces with care when installing the cladding.

Additional information and source

For more information, consult your nearest Lunawood® dealer.

Source: Wooden external cladding, Finnish Timber Council (www.puuinfo.fi)